

Part numbers contained in this manual were in effect at the time the manual was approved for printing and are subject to change without notice or liability, Fabco Automotive Corporation reserves the right to change parts at any time.

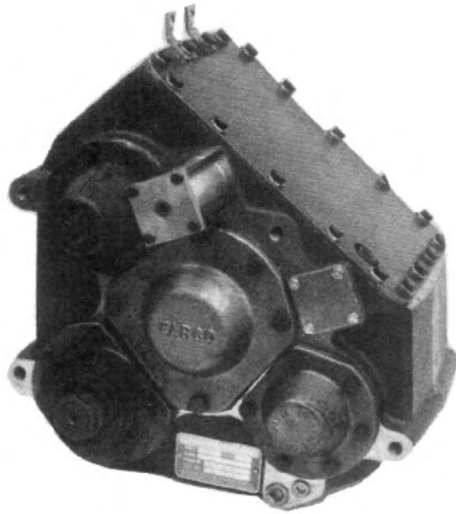

TC-38

Transfer Case

PARTS MANUAL

Before ordering parts for a Fabco transfer case, please refer to the Fabco nameplate located on the transfer case housing. Specify model number, serial number, part number, or other information that is on the nameplate when ordering parts.

FOOTNOTES:

★ 1. Select shims (Item #71) to achieve .003 to .008 end float.

2. Models with mechanically driven speedometer.

3. Models with electronic speedometer.

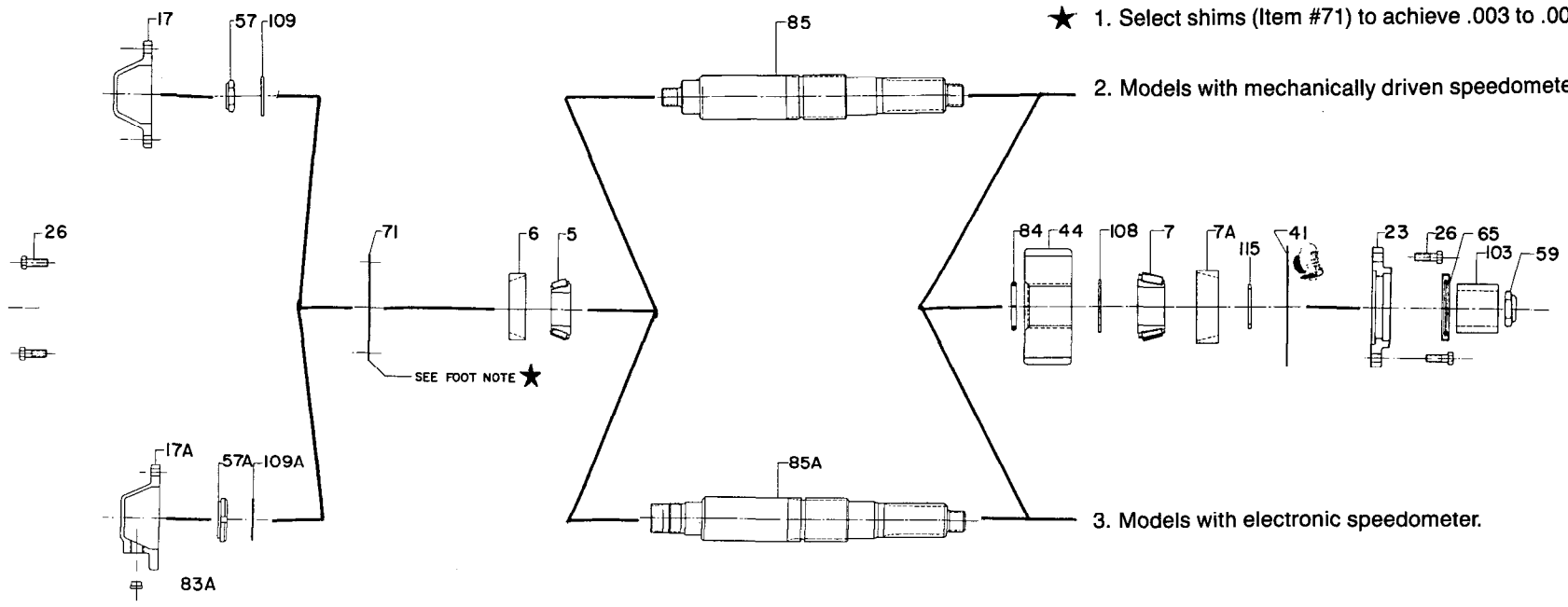

ITEM	PART NO.	DESCRIPTION	QTY	FOOT NOTE					
					71	7441322	Shim, Coral .031	A/R	
						7442322	Shim, Pink .016	A/R	1
						7443322	Shim, Blue .005	A/R	
						7444322	Shim, Red .002	A/R	
5	233 455	Bearing, Cone	1		83A	758 374 108	Plug, Speedo Shipping	1	3
6	233 456	Bearing, Cup	1		84	762 292	Ring, Split Retaining	1	
7	233 457	Bearing, Cone	1		85	769 456	Shaft, Rear Output	1	2
7A	233 458	Bearing, Cup	1		85A	769 466	Shaft, Rear Output	1	3
17	235 484	Cap, Output Shaft Bearing	1	2	103	883 988	Tube, Shipping Oil Seal Protector	1	
17A	235 632	Cap, Speedo	1	3	108	927 758	Washer, Bearing Spacer Rear Output	1	
23	237 589	Carrier, Rear Output	1		109	927 775 001	Washer, Rear Output Shaft Front (1.062 ID x 2.25 OD x .187 Thk)	1	2
26	265 238	Bolt, HH 7/16-14 NC 1 1/4	12		109A	927 829	Washer, Rear Output Shaft Front (1.78 ID x 2.25 OD x .125 Thk)	1	3
41	427 466	Gasket, Rear Output Seal Carrier	1		115	927 828	Washer, Between Bearing & Yoke (1.957 ID x 2.50 OD x .125 Thk)	1	
44	432 554	Gear, 35T Rear Output	1						
57	688 634	Nut, 1-20 Self Locking	1	2					
57A	688 743	Nut, 1.767-18 Bearing Lock	1	3					
59	688 697 004	Nut, 1 1/2-12 Self Locking	1						
65	732 372	Seal, Rear Output	1						

TC-38 REAR OUTPUT SHAFT

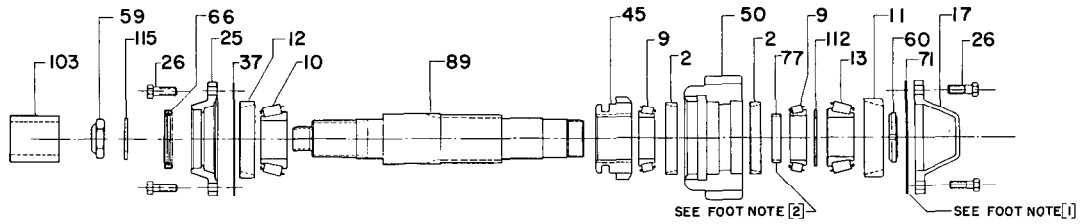

ITEM	PART NO.	DESCRIPTION	QTY	FOOT NOTE
2	233 274	Bearing, Cup	2	
9	233 485	Bearing, Cone	2	
10	233 487	Bearing, Cone	1	
11	233 545	Bearing, Cup	1	
12	233 547	Bearing, Cup	1	
13	233 548	Bearing, Cone	1	
17	235 484	Cap, Output Shaft Bearing	1	
25	237 587 002	Carrier, Front Output Seal	1	
26	265 238	Bolt, HH 7/16-14 NC 1 1/4	12	
37	427 339	Gasket, Carrier	1	
45	432 556	Gear, 20T Clutch	1	
50	432 677	Gear, 35T Front Output	1	
59	688 697 004	Nut, 1 1/2-12 Self Locking	1	
60	688 739	Nut, 1 3/32-18 Bearing Lock	1	
66	732 384	Seal, Front Output	1	
71	7441322	Shim, Coral .031	A/R	
	7442322	Shim, Pink .016	A/R	1
	7443322	Shim, Blue .005	A/R	
	7444322	Shim, Red .002	A/R	
77	756 268 011	Ring, Brg Spcr .560 Thk	A/R	
	756 268 012	Ring, Brg Spcr .565 Thk	A/R	
	756 268 013	Ring, Brg Spcr .570 Thk	A/R	2
	756 268 014	Ring, Brg Spcr .575 Thk	A/R	
	756 268 015	Ring, Brg Spcr .580 Thk	A/R	
89	769 455	Shaft, Front Output	1	
103	883 988	Tube, Shipping Oil Seal Protector	1	
112	927 827 001	Washer, Front Output Shaft Rear (2.010 ID x 2.75 OD x .145 Thk)	1	
115	927 828	Washer, Between Bearing & Yoke (1.957 ID x 2.50 OD x .125 Thk)	1	

FOOTNOTES:

1. Select shims (Item #71) to achieve .003 to .008 end float.
2. Select correct bearing spacer ring thickness (Item #77) to achieve .003 to .008 end float.

TC-38 FRONT OUTPUT SHAFT

FOOTNOTES:

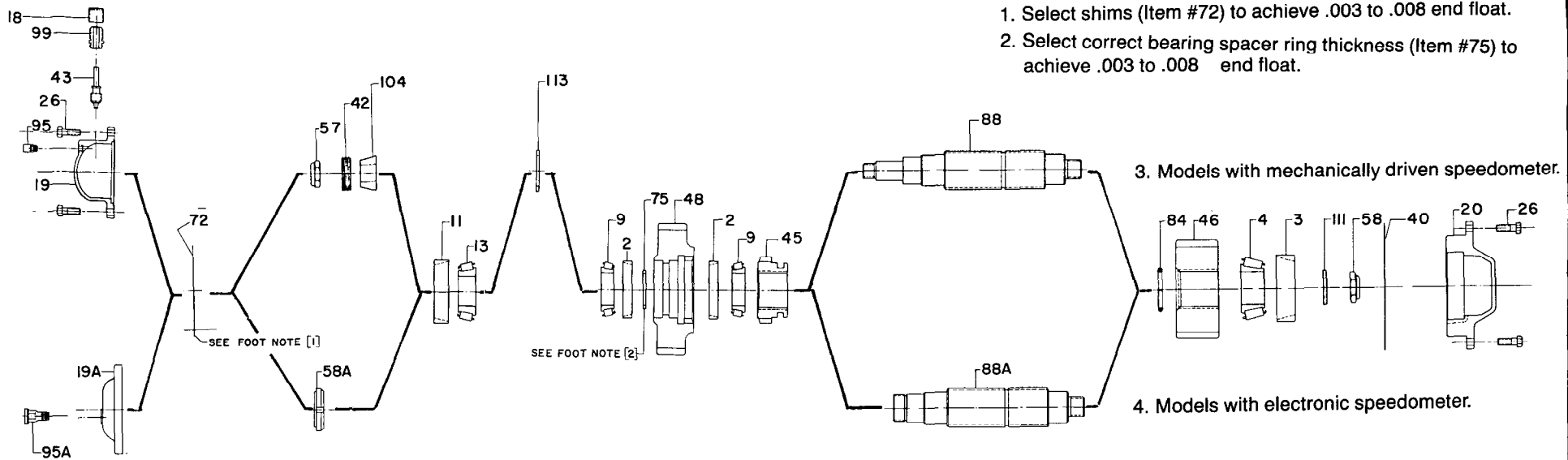

ITEM	PART NO.	DESCRIPTION	QTY	FOOT NOTE					
2	232 274	Bearing, Cup	2		72	744 352 001	Shim, Red .002	A/R	
3	233 376	Bearing, Cup	1			744 352 002	Shim, Blue .005	A/R	1
4	233 377	Bearing, Cone	1			744 352 003	Shim, Pink .015	A/R	
9	233 485	Bearing, Cone	2			744 352 004	Shim, Coral .030	A/R	
11	233 545	Bearing, Cup	1		75	756 268 001	Ring, Brg Spcr .250 Thk	A/R	
13	233 548	Bearing, Cone	1			756 268 002	Ring, Brg Spcr .255 Thk	A/R	
18	235 529	Cap, Speedo, Shipping	1	3		756 268 003	Ring, Brg Spcr .260 Thk	A/R	2
19	235 622	Cap, Intermediate Front	1	3		756 268 004	Ring, Brg Spcr .265 Thk	A/R	
19A	235 629	Cap, Intermediate Front	1	4		756 268 005	Ring, Brg Spcr .270 Thk	A/R	
20	235 623	Cap, Intermediate Rear	1						
26	265 238	Bolt, HH 7/16-14 NC x 1 1/4	12		84	762 292	Ring, Split Ret.	1	
40	427 529	Gasket, Intermediate Rear Cap	1		88	769 454	Shaft, Intermediate	1	3
42	432 234	Gear, Speedo Drive 4T	1	3	88A	769 467	Shaft, Intermediate	1	4
43	432 235	Gear, Speedo Driven 17T	1	3	95	836 222	Vent	1	3
45	432 556	Gear, 20T Clutch	1		95A	836 223	Vent	1	4
46	432 558	Gear, 34T Direct	1		99	883 473	Tube, Speedo Driven Gear	1	3
48	432 675	Gear, 41T Underdrive	1		104	884 228	Tube, Spacer Speedo Gear, .829 Thk	1	3
57	688 634	Nut, 1-20 Self Locking	1	3	111	927 775 007	Washer, Intermediate Shaft Rear (1.540 ID x 2.50 OD x .250 Thk)	1	
58	688 694	Nut, 1 1/2-12 Self Locking	1		113	927 827 003	Washer, Intermediate Shaft Front (2.010 ID x 2.75 OD x .080 Thk)	1	3
58A	688 739	Nut, 1 3/32-18 Bearing Lock	1	4					

TC-38 INTERMEDIATE SHAFT

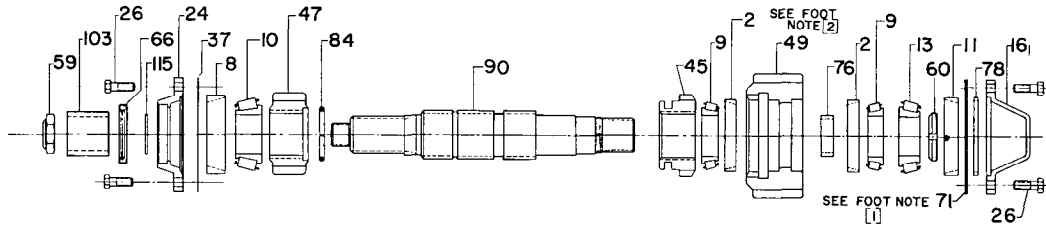

ITEM	PART NO.	DESCRIPTION	QTY	FOOT NOTE
2	233 274	Bearing, Cup	2	
8	233 479	Bearing, Cup	1	
9	233 485	Bearing, Cone	2	
10	233 487	Bearing, Cone	1	
11	233 545	Bearing, Cup	1	
13	233 548	Bearing, Cone	1	
16	235 375 002	Cap, Input Shaft Rear	1	
24	237 587 001	Carrier, Seal, Input	1	
26	265 238	Bolt, HH 7/16-14 NC x 1 1/4	12	
37	427 339	Gasket, Carrier	1	
45	432 556	Gear, 20T Clutch	1	
47	432 674	Gear, 19T Underdrive Pinion	1	
49	432 676	Gear, 35T Input	1	
59	688 697 004	Nut, 1 1/2-12 Self Locking	1	
60	688 739	Nut, 1 3/32-18 Bearing Lock	1	
66	732 384	Seal, Input & Front Output	1	
71	7441322	Shim, Coral .031	A/R	
	7442322	Shim, Pink .016	A/R	1
	7443322	Shim, Blue .005	A/R	
	7444322	Shim, Red .002	A/R	
76	756 268 006	Ring, Brg Spcr .435 Thk	A/R	
	756 268 007	Ring, Brg Spcr .440 Thk	A/R	
	756 268 008	Ring, Brg Spcr .445 Thk	A/R	2
	756 268 009	Ring, Brg Spcr .450 Thk	A/R	
	756 268 010	Ring, Brg Spcr .455 Thk	A/R	
78	756 269	Ring, Space Input Shaft Rear ,278 Thk	1	
84	762 292	Ring, Split Ret.	1	
90	769 453	Shaft, Input	1	
103	883 988	Tube, Shipping, Oil Seal Protector	1	
115	927 828	Washer, Between Bearing & Yokes (1.957 ID x 2.50 OD x .125 Thk)	1	

FOOTNOTES:

1. Select shims (Item #71) to achieve .003 to .008 end float.
2. Select correct bearing spacer ring thickness (Item #76) to achieve .003 to .008 end float.

TC-38 INPUT SHAFT

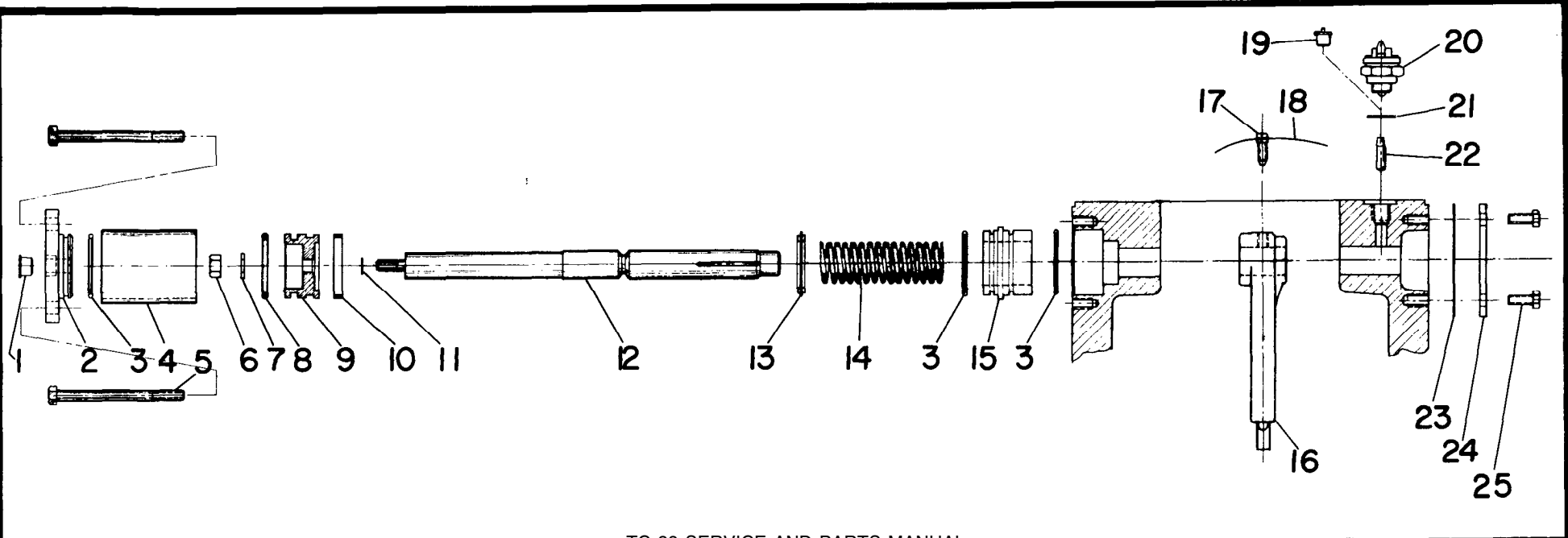

TC 38 SERVICE AND PARTS MANUAL

ITEM	PART NO.	DESCRIPTION	QUANTITY
1	758 338	Plastic Plug	1
2	235 352	Cap, Air Shift Cyl.	1
3	675 224	O-Ring, Air Shift Cap & Adaptor	3
4	883 887 006	Tube, Air Shift	1
5	265 892	Capscrew, Shift Cyl. Mtg.	4
6	688 464	Nut, Shift Piston	1
7	927 643	Washer, Shift Piston	1
8	675 326	O-Ring, Shift Piston	1
9	753 232	Piston, Shift	1
10	339 223	Felt Ring, Shift Piston	1
11	782 288	O-Ring, Shift Shaft	1
12	769 285	Shaft, Air Front Drive Shift	1
13	736 747	Ring, Nylon Bump	1

ITEM	PART NO.	DESCRIPTION	QUANTITY
14	777 485	Spring, Air Shift Return	1
15	883 479	Adaptor, Air Shift Cyl.	1
16	367 295	Fork, Front Drive Shift	1
17	724 222	Set Screw	1
18	947 223	Lockwire	1
19	758 364	Plastic Plug	1
20	798 245	Switch, Indicator	1
21	927 427	Washer, Copper	1
22	746 678	Dowel, Switch Operating	1
23	427 399	Gasket, Shift Shaft Cap	1
24	235 372	Cap, Shift Shaft	1
25	265 343	Capscrew, 1/4-20 x 1/2	4

Air Operated Front Drive Declutch

AIR OPERATED H-U AND H-N-U

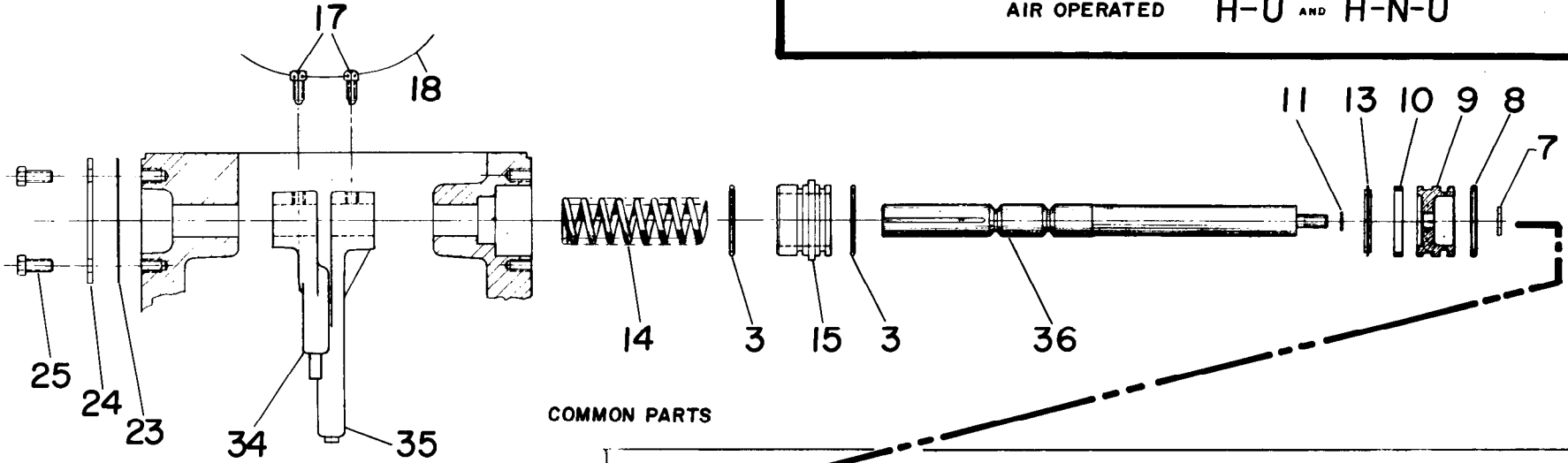

COMMON PARTS

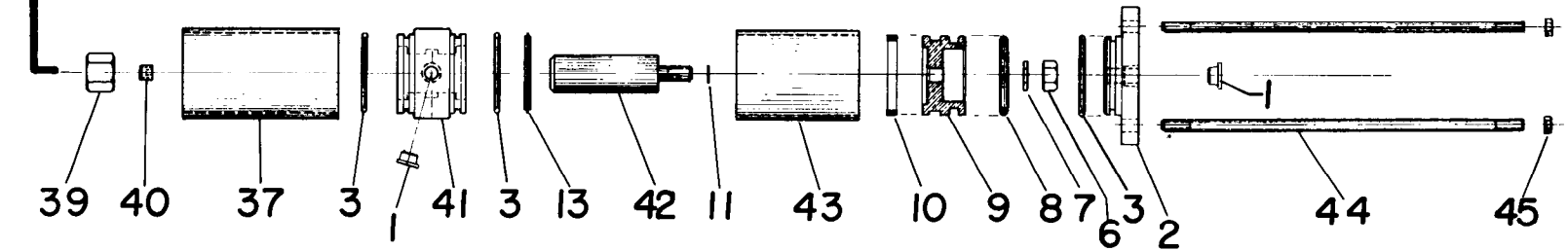
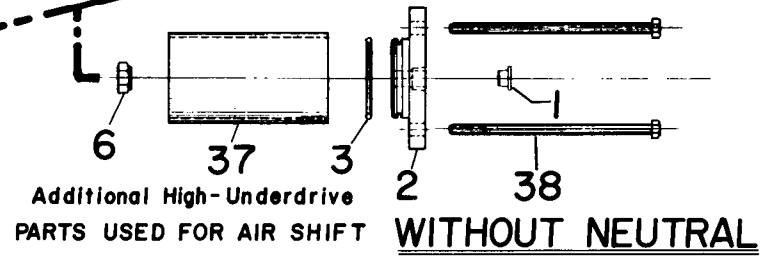

ADDITIONAL HIGH-NEUTRAL-UNDERDRIVE PARTS WITH NEUTRAL (Required with PTO and Air Shift)

H-N-U Air Shift

ITEM	PART NO.	DESCRIPTION	QUANTITY
1	758 338	Plastic Plug	2
2	235 352	Cap, Air Shift Cyl.	1
3	675 224	O-Ring, Air Shift & Adaptor	5
6	688 464	Nut, Shift Piston	1
7	927 643	Washer, Shift Piston	2
8	675 326	O-Ring, Shift Piston	2
9	753 232	Piston, Shift	2
10	339 223	Felt Ring, Shift Piston	2
11	782 288	O-Ring, Shift Shaft	2
13	736 747	Ring, Nylon Bump	2
14	777 485	Spring, Air Shift Return	1
15	883 479	Adaptor, Air Shift Cyl.	1
17	724 222	Set Screw	2
18	947 223	Lockwire	2
23	427 399	Gasket, Shift Shaft Cap	1
24	235 372	Cap, Shift Shaft	1
25	265 343	Capscrew, 1/4-20 x 1/2	4
34	367 294	Fork, Direct Drive Shift	1
35	367 268	Fork, Under Drive Shift	1
36	742 877	Shaft, H-N-U Air Shift	1
37	883 887 003	Tube, Shift Cyl.	1
39	688 643	Nut, Special	1
40	724 582	Set Screw, 3/8-24 x 1/4 Allan Head	1
41	883 893	Adaptor, Piggyback Cyl.	1
42	769 286	Shaft, Piggyback Cyl.	1
43	883 887 007	Tube, Piggyback Cyl. & PTO Cyl.	1
44	788 546 006	Stud, Piggyback Cyl. Mtg.	4
45	688 323	Nut, 1/4-28	4

H-U Air Shift

ITEM	PART NO.	DESCRIPTION	QUANTITY
1	758 338	Plastic Plug	1
2	235 352	Cap, Air Shift Cyl.	1
3	675 224	O-Ring, Air Shift Cap & Adaptor	3
6	688 464	Nut, Shift Piston	1
7	927 643	Washer, Shift Piston	1
8	675 326	O-Ring, Shift Piston	1
9	753 232	Piston, Shift	1
10	339 223	Felt Ring, Shift Piston	1
11	782 288	O-Ring, Shift Shaft	1
13	736 747	Ring, Nylon Bump	1
14	777 485	Spring, Air Shift Return	1
15	883 479	Adaptor, Air Shift Cyl.	1
17	724 222	Set Screw	2
18	947 223	Lockwire	2
23	427 399	Gasket, Shift Shaft Cap	1
24	235 372	Cap, Shift Shaft	1
25	265 343	Capscrew 1/4-20 x 1/2	4
34	367 294	Fork, Direct Drive Shift	1
35	367 268	Fork, Under Drive Shift	1
36	742 877	Shaft H-N-U Air Shift	1
37	883 887 003	Tube, Shift Cyl.	1
38	265 982	Capscrew, Air Shift Cyl. 1/2-20 x 4 3/4	4

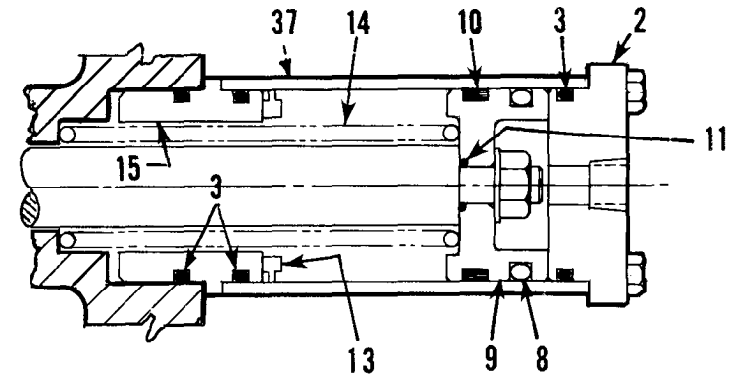
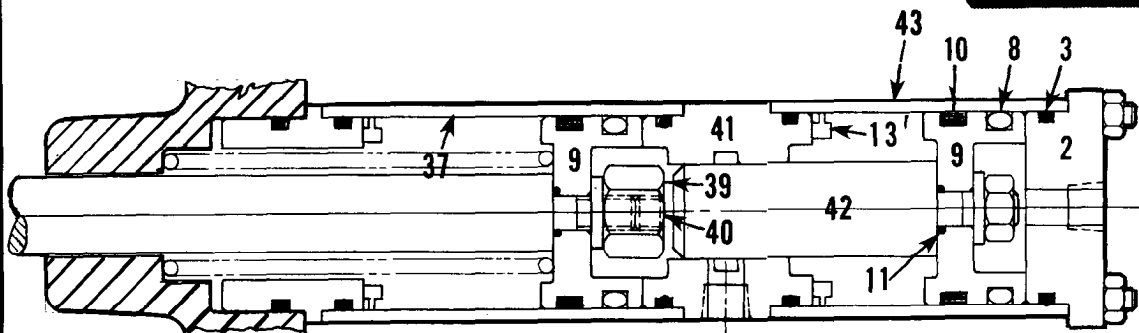

PARTS NOT DESIGNATED ON A DRAWING

ITEM	PART NO.	DESCRIPTION	QUANTITY
51	478 254	Housing, Main Case	1
94	793 377	Cover, Main Case	1
39	427 464	Gasket, Main Cover	1
32	273 687	Bracket, Case Lifting	2
27	265 239	Capscrew, Cover Mtg. $\frac{7}{16}$ -14 x 1	16
26	265 238	Capscrew, Cover Mtg. $\frac{7}{16}$ -14 x 1 $\frac{1}{4}$	2
107	927 749	Washer: Cover Mtg. Screw $\frac{7}{16}$ Lock	18
52	626 228	Label, Serial Plate	1
62	724 276	Screw, Serial Plate Mtg. Drive	2
80	758 274	Plug, $\frac{3}{4}$ NPT Magnetic Drain	1
79	758 229	Plug, $\frac{3}{4}$ NPT Fill and Level	2
81	758 293	Plug, $\frac{1}{2}$ NPT Return Line Hole	1

REFER TO FIGS. 1 AND 2 (PAGE 2)