



TC-142 PD TRANSFER CASE SERVICE MANUAL

TABLE OF CONTENTS

	SECTION
<u>TC-142 PD TRANSFER CASE SERVICE MANUAL</u>	1.0
Introduction	1.1
Operation	1.2
Specification	1.3
<u>LUBRICATION</u>	2.0
<u>CLEANING & INSPECTION</u>	3.0
<u>GENERAL INSTRUCTIONS</u>	4.0
<u>DISASSEMBLY</u>	5.0
<u>ASSEMBLY</u>	6.0
Intermediate Shaft	6.1
Upper Shaft.....	6.2
Lower Shaft Sub-Assembly.....	6.3
Lower Shaft Installation	6.4
Bearing Adjustment	6.5
Shift Shaft.....	6.6
Declutches	6.7
Pump & Plumbing.....	6.8
<u>TORQUE SPECIFICATIONS</u>	7.0
<u>ILLUSTRATED PARTS</u>	8.0
<u>PARTS LIST</u>	9.0
<u>TOOLS</u>	10.0

1.1 INTRODUCTION

The Fabco TC-142 PD transfer case with proportional differential is a two-speed unit designed for **full-time** all wheel drive vehicles. Two proportioning ratios are available; 26/74 and 50/50. The 26/74 differential proportions 26% of the input torque to the front axle and 74% to the rear, while the 50/50 model divides the torque equally.

This manual is a supplement and must be used in conjunction with the Fabco TC-142 Transfer Case Parts and Service Manual.

1.2 OPERATION

For normal operation, the transfer case differential control should be in the **unlocked** position. It may be shifted to the locked position when conditions require increased traction. The differential control can be locked or unlocked while the vehicle is either stationary or in motion, **provided the wheels are not slipping**. Shifts between ranges, however, must be made while the vehicle is stationary to avoid serious damage to the transfer case. The vehicle should not be operated under normal traction conditions with the differential control locked.

Important: When testing any vehicle equipped with a proportional differential transfer case on a chassis dynamometer, it is necessary to disconnect the front driveline at the transfer case and operate the unit with the differential control in the locked position. These instructions must be followed because the transfer case is not designed for continuous operation with one output shaft turning while the other is stationary. Serious damage will occur to the internal differential parts due to excessive speed. Also, when towing any vehicle equipped with a proportional differential transfer case, both the front and rear drivelines must be disconnected for the same reasons.

1.3 SPECIFICATIONS

RATINGS

Maximum Input Torque	14,000 Lbs. Ft.
Maximum Input Horsepower	500 HP
Maximum Input Speed	2,300 RPM

RATIOS

Direct	1:1
Underdrive	2.23:1

GEAR TYPE

Helical, Case Hardened

INPUT

2.75-10 Spline

REAR AXLE OUTPUT

2.75-10 Spline

FRONT AXLE OUTPUT

1.97-10 Spline

DROP

16"

SHIFT MECHANISM

Integral Air Cylinder

LUBRICATION SYSTEM

Gear Pump - 30 PSI - 4 GPM Approximately

LUBRICANT

See Lubrication Section

OIL CAPACITY

22 Quarts Est. *

WEIGHT

1,250 Lbs.

* The oil should be filled to the level of the fill plug regardless of the amount used.

2.0 LUBRICATION

See Section 2.0 in the Fabco TC-142 Transfer Case Parts and Service Manual.

3.0 CLEANING AND INSPECTION

See Section 3.0 in the Fabco TC-142 Transfer Case Parts and Service Manual.

4.0 GENERAL INSTRUCTIONS

See Section 4.0 in the Fabco TC-142 Transfer Case Parts and Service Manual.

5.0 DISASSEMBLY

1. Follow the instructions in Fig. 5.1-1 through Fig. 5.1-3 in the Fabco TC-142 Transfer Case Parts and Service Manual. Remove the PTO declutch assembly if the unit is so equipped. See Fig. 5.1-4.
2. Remove the front output yoke or companion flange.
3. Remove the front lockout shift cylinder parts, indicator switch & pin and the lockout housing cover. Cut the lockwire and remove the (2) shift fork clamping screws. Withdraw the shift shaft. See figures on Sect. 6 Page 18, in the Fabco TC-142 Transfer Case Parts and Service Manual.
4. Remove the (8) capscrews securing the front output carrier to the lockout housing. Pull off the carrier and discard the gasket. The front output shaft bearings are installed with a light press fit, and therefore, some force may be necessary - use care not to damage the gasket surface. Pull off the remaining bearing cone and remove the clutch gear. Remove the "C" shaped retaining ring from the inner shaft.

5. Follow the instructions in Fig. 5.1-5 through Fig. 5.1-10 in the Fabco TC-142 Transfer Case Parts and Service Manual.
6. Remove the rear output yoke or companion flange.
7. Remove the speedometer adapter and pinion gear from the rear output seal carrier. Remove the (6) capscrews securing the carrier. Remove the carrier and discard the gasket. Remove and discard the oil seal from the carrier.

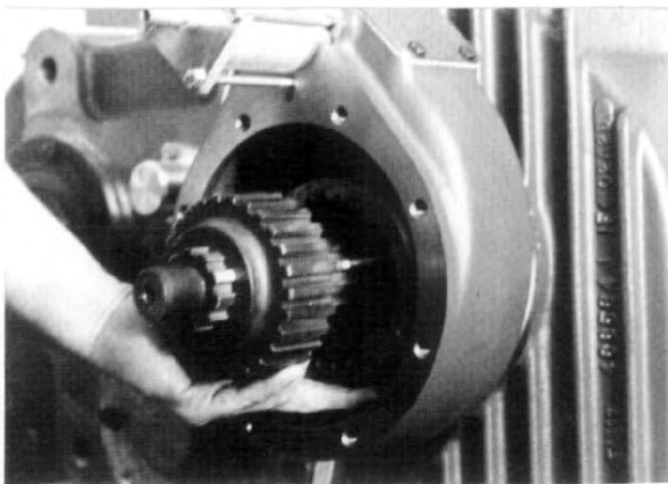
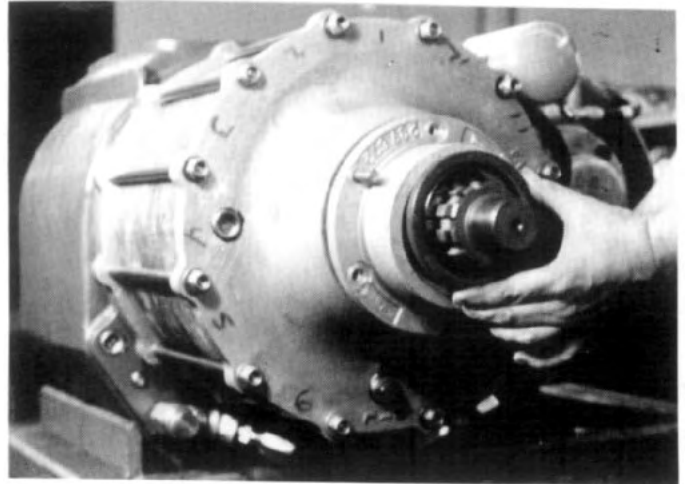

8. Remove the (12) nuts (50/50 model) or capscrews (26/74 model) securing the rear output shaft carrier to the inner differential housing carrier. Remove the rear output shaft with its carrier as an assembly. Remove the outer differential housing and discard the O-rings. Remove the (12) studs (50/50)

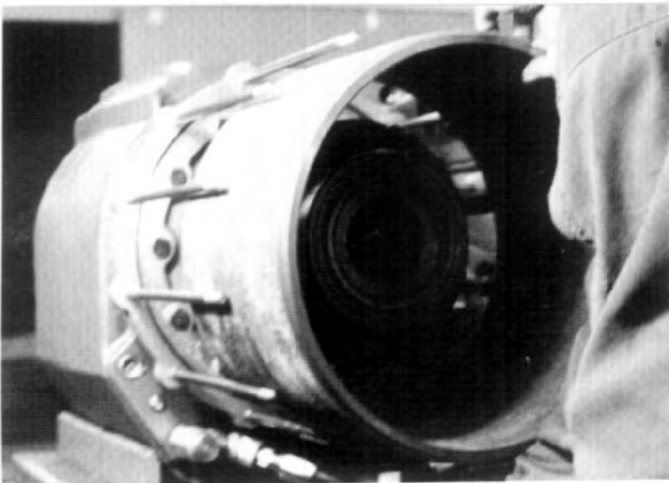
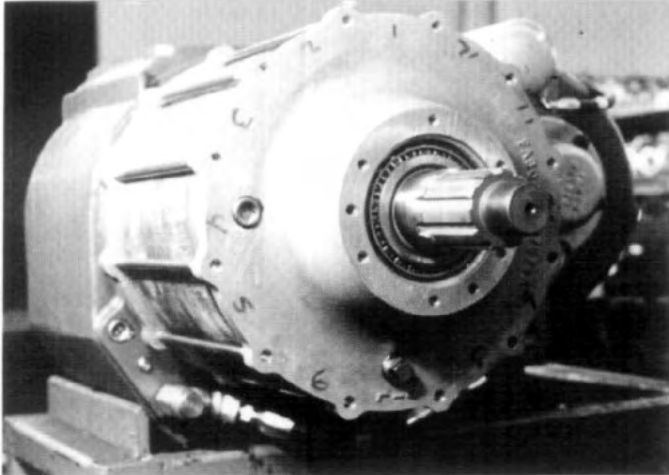

9. If working on a 50/50 differential, remove the (8) differential housing bolts and nuts. Remove the rear housing and the internal differential parts.

If working on a 26/74 differential, remove the (3) planet pin snap rings. Remove the planet pins, planet gears, rollers, and spacer from the planet carrier.

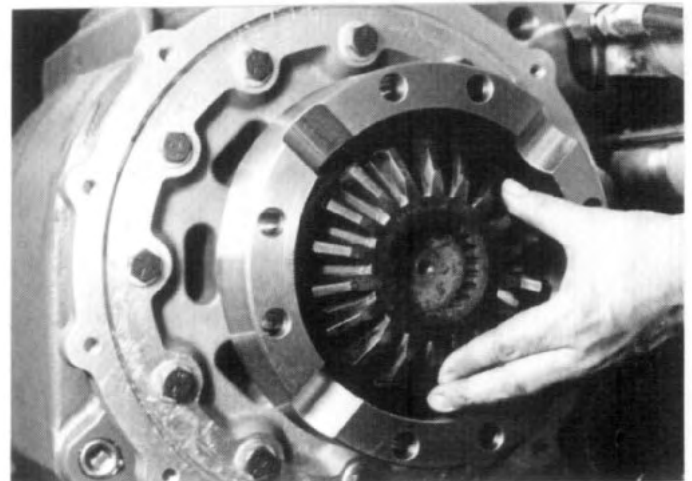
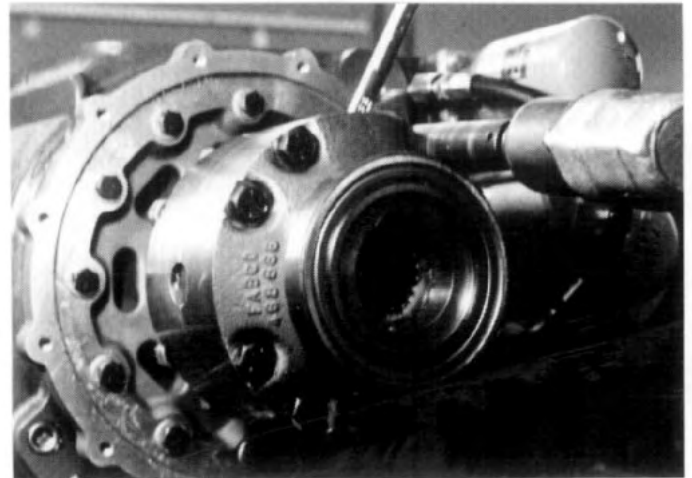

10. Remove the inner shaft rearward. Remove the front differential housing or planet carrier retaining nut with Fabco Tool 866 670 or equivalent. Remove the housing or carrier.

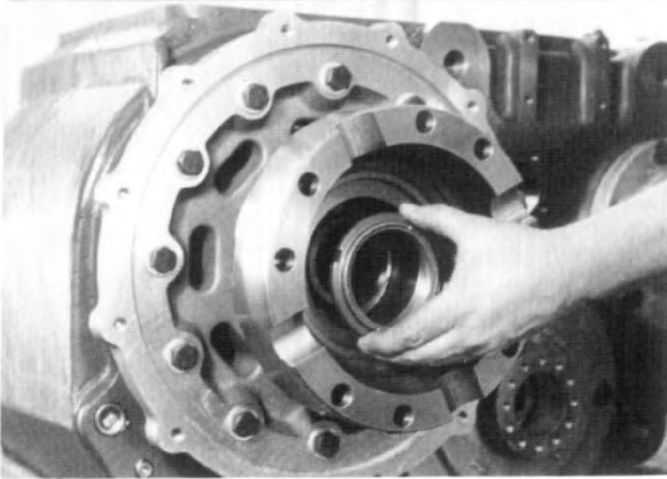

11. Remove the (6) capscrews securing the front lockout housing to the main housing and remove the housing.

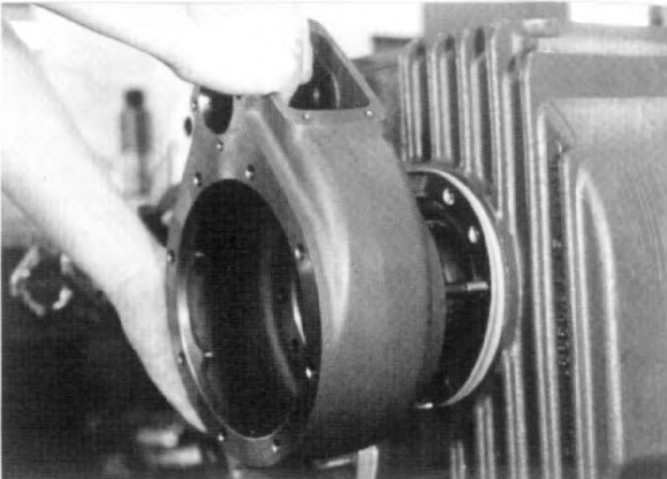

12. Continue disassembly by following Fig. 5.1-12 through Fig. 5.1-19 in the Fabco TC-142 Transfer Case Parts and Service Manual.

13. Tap or press the rear output shaft through the rear output shaft carrier. If working on a 50/50 model, remove and discard the oil seal.



6.0 ASSEMBLY

See Section 6.0 in the Fabco TC-142 Transfer Case Parts and Service Manual.

6.1 INTERMEDIATE SHAFT

See Section 6.1 in the Fabco TC-142 Transfer Case Parts and Service Manual.

6.2 UPPER SHAFT

See Section 6.2 in the Fabco TC-142 Transfer Case Parts and Service Manual.

6.3 LOWER SHAFT SUB-ASSEMBLY

1. Press the bearing cups into both lower gears.
2. Place the end of the outer lower shaft with the smaller diameter threads into the assembly stand (similar to Fig. 6.3-1 in the Fabco TC-142 Transfer Case Parts and Service Manual).
3. Slip a gear bearing cone onto the shaft. See Fig. 6.3-3 in the Fabco TC-142 Transfer Case Parts and Service Manual. Install the smaller gear, the bearing spacer, and the second bearing cone. See Fig. 6.3-5 in the Fabco TC-142 Transfer Case Parts and Service Manual.
4. Check and adjust the gear end float as instructed in Fig. 6.3-6 in the Fabco TC-142 Transfer Case Parts and Service Manual using Fabco Tool 866 676 instead of 866 649 shown.

5. Install the shaft bearing as instructed in Fig. 6.3-7 and Fig. 6.3-8 in the Fabco TC-142 Transfer Case Parts and Service Manual.
6. After the bearing cools, reverse the shaft in the fixture and slip the clutch collar into place. Repeat the procedure with the larger gear using Fabco Tool 866 650 to check and adjust the gear end float. See Fig. 6.3-9 and Fig. 6.3-11 in the Fabco TC-142 Transfer Case Parts and Service Manual. **Do not install the shaft bearing at this time.**

6.4 LOWER SHAFT INSTALLATION

1. Follow the directions in Fig. 6.4-1 through Fig. 6.4-10 in the Fabco TC-142 Transfer Case Parts and Service Manual.
2. Press the bearing cup into the inner differential housing carrier. Install the carrier and a new gasket to the main housing. Torque the (11) capscrews to specification.

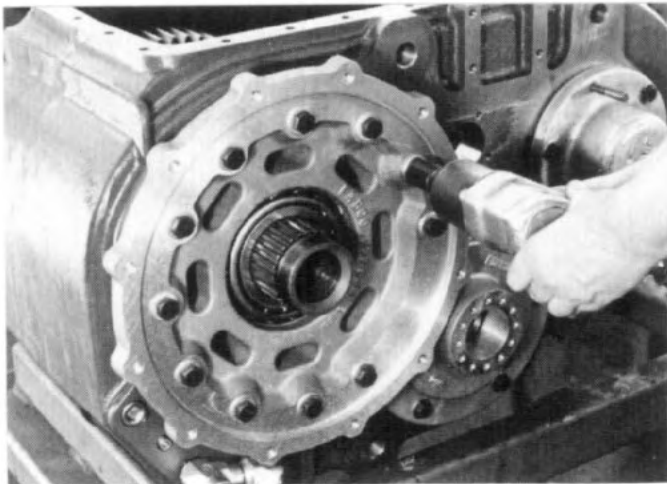

3. Slip the front differential housing (50/50) or planet carrier (26/74) onto the rear of the outer shaft. Install its attaching locknut and torque to specification.

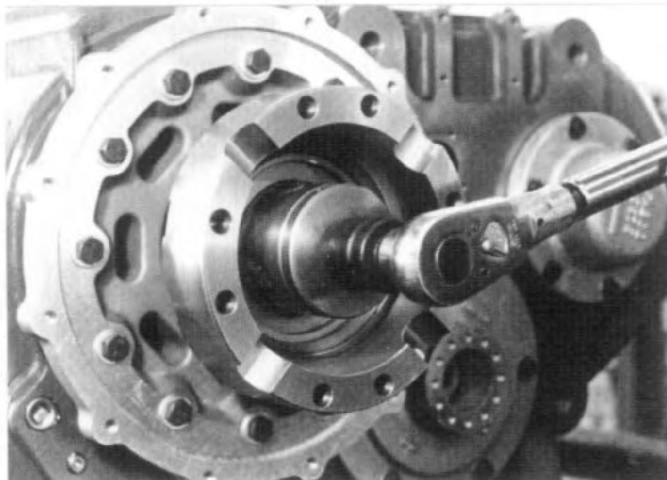

4. The lower shaft end float must be set at this time. Follow the directions in Section 6.5 in the Fabco TC-142 Transfer Case Parts and Service Manual.

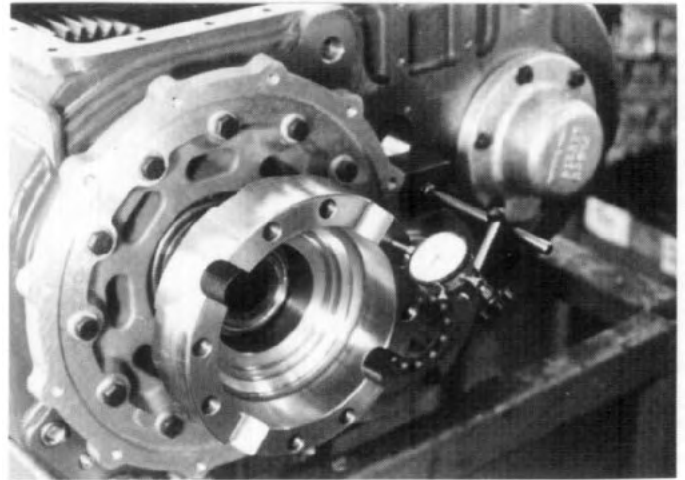

5. Insert the differential lockout collar together with its shift fork into the front lockout housing. Be sure to observe the orientation of these parts. The longer end on the collar must face inward and the fork must have its clamp bolt heads accessible from the opening in the lockout housing.

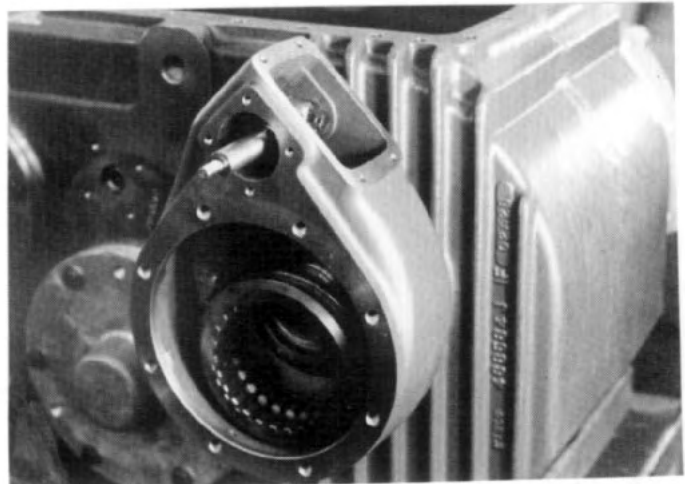

6. If working on a 50/50 differential model skip to Step 7. Otherwise, install the round retaining ring in its groove on the rear of the inner shaft (shorter splined end). Install the sun gear and its snap ring.

- The inner shaft must be installed from the rear. Slip the inner shaft into the outer shaft and push all the way forward. Working inside the front differential lockout housing, install the inner shaft "C" shaped retaining ring. Slide the shift shaft into the fork and add the clamp bolts. See Fig. 6.7-4 in the Fabco TC-142 Transfer Case Parts and Service Manual. Follow the directions in Fig. 6.7-5 through Fig. 6.7-7.

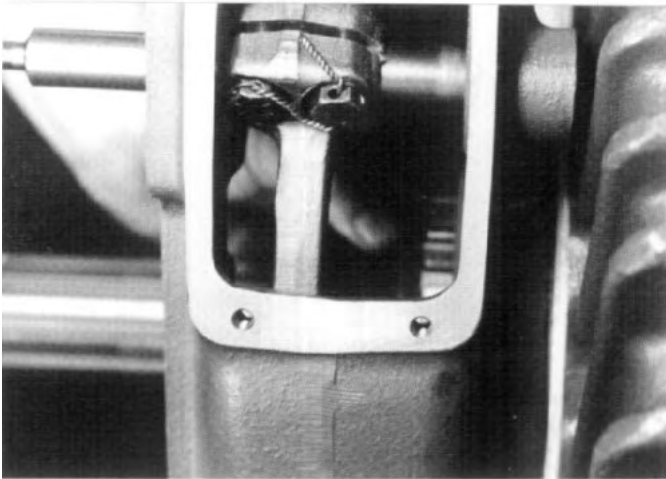

- Slip the differential lockout gear onto the shaft and inside the shift collar. Heat and install one of the front inner shaft bearing cones. Slip the bearing spacer onto the shaft.

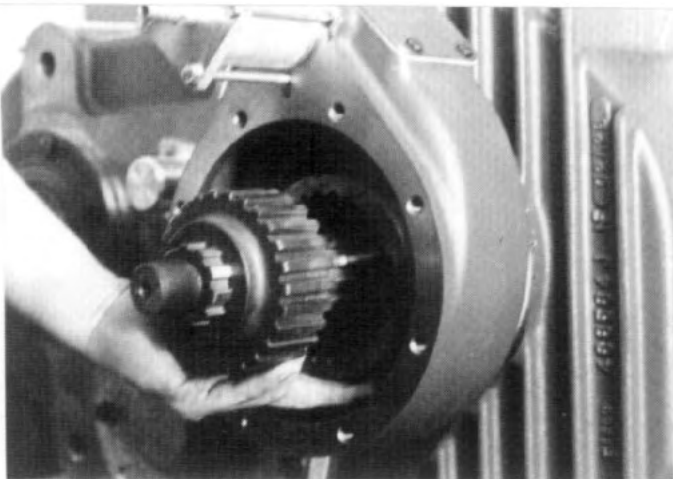

- Press the bearing cups into the differential lockout carrier. Install the carrier and its gasket to the lockout housing. Torque the (8) capscrews to specification. Heat and install the remaining bearing cone. Temporarily install Fabco Tool 866 677 with the yoke flange retaining locknut.

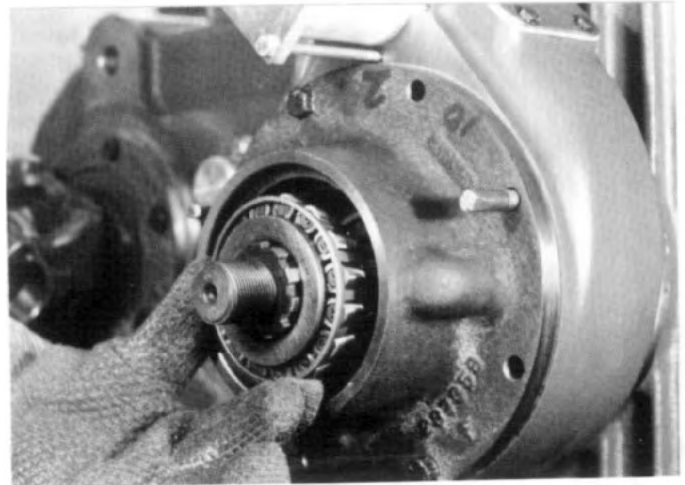

- After the assembly cools to room temperature, check the inner shaft end float with a dial indicator. If the end float is not within specification (.003 to .008) the carrier must be removed and the bearing spacer replaced with one of the proper width to obtain the correct end float.
- Remove Tool 866 677. Press a new shaft seal into the lockout carrier and install the front drive yoke or companion flange. Torque the locknut to specification.

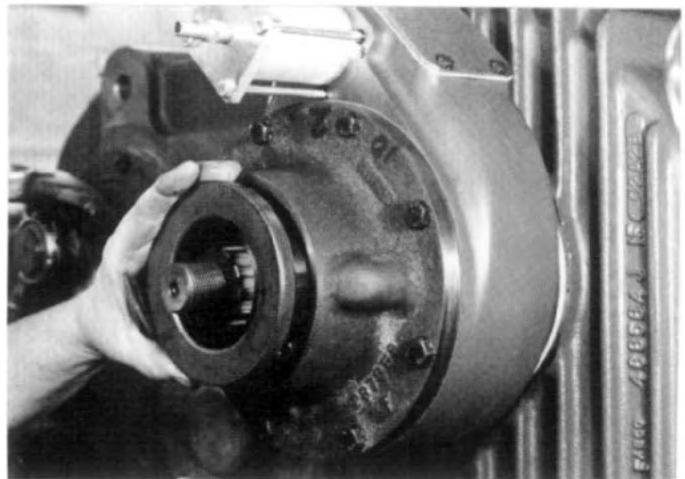

12. Assemble the differential assembly as follows:

Liberal smearing differential components with grease slurry.

50/50 Differential

- a. Heat and install the ball bearing assembly onto the rear differential case housing. The shielded end must face away from the housing.



- b. Insert the thick thrust washer into the front differential case housing. The grooves in the washer should be facing rearward. Slip a thin flat thrust washer onto one of the differential side gears and place into the differential assembly engaging the splines with the inner shaft.

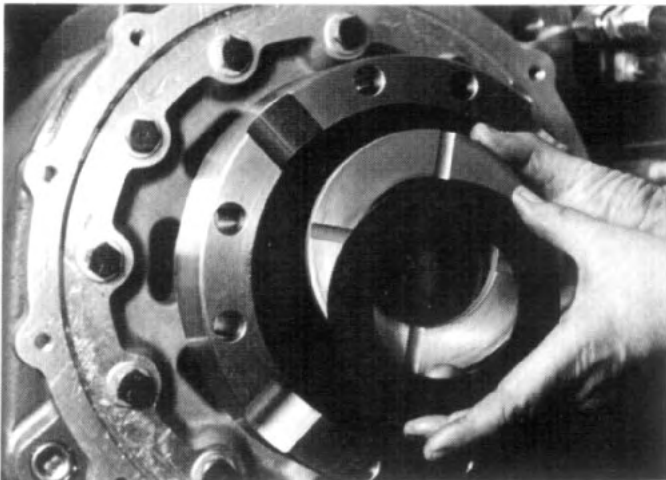

- c. Slip the remaining flat thrust washer onto the remaining differential side gear and place into the rear differential housing.

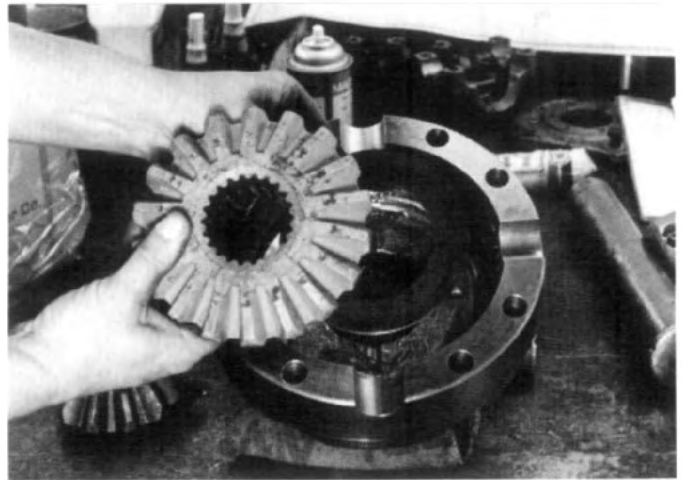

- d. Place a differential pinion gear and a spherical thrust washer on each of the four legs of the differential cross and insert into the rear differential case housing.

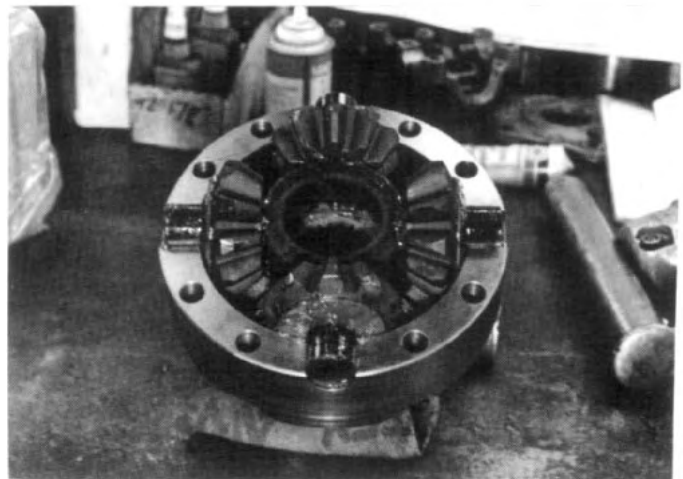

- e. Joint the two differential case housings together and attach with the (8) bolts and nuts. Torque to specification. Check to see that the differential assembly rotates freely.

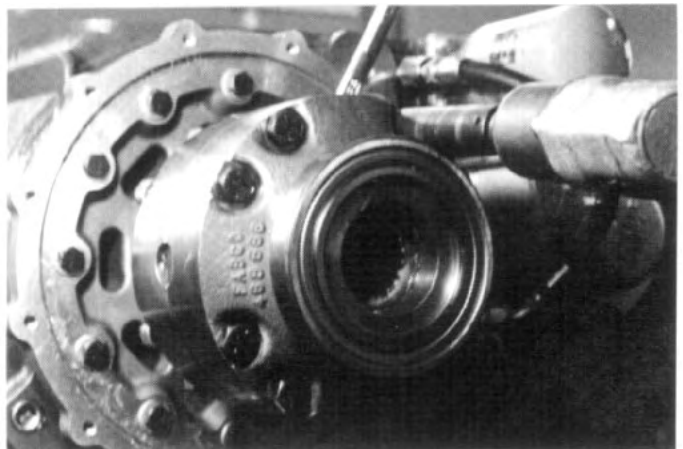

- f. Install the (12) long studs into the inner differential housing carrier.

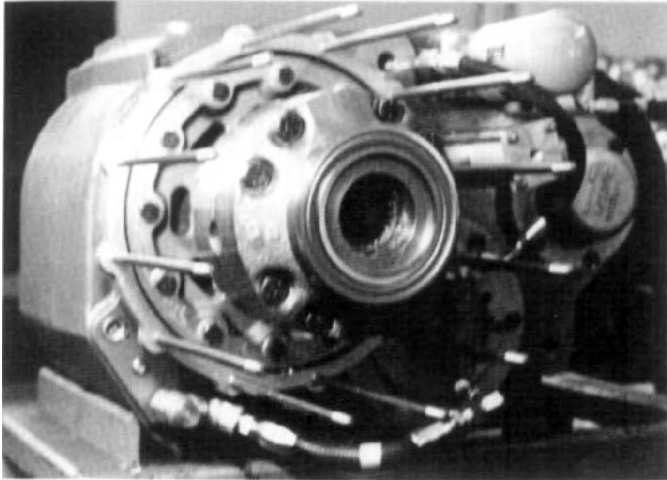

14. Heat and install a bearing cone onto the rear output shaft. Slip the bearing spacer into position and place into the rear differential housing carrier. Heat and install the remaining bearing cone.



26/74 Differential

- a. Install (3) roller bearing assemblies and (2) spacers into each planet gear. Insert into the planetary carrier, add a planet pin spacer on each side of the planet gear, and slide the planet pin through.
- b. Install the planet pin retaining snap rings. Check to see that the assembly rotates freely.
- c. Attach the internal gear to the rear output shaft and torque the (12) attaching capscrews to specification.
13. Press the bearing cups into the rear output shaft carrier.

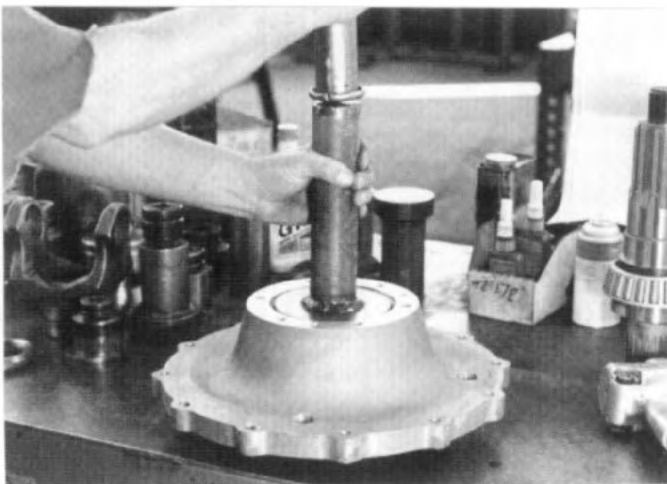

15. Temporarily install Fabco Tool 866 678 with the yoke or flange retaining locknut. After the assembly cools to room temperature, check the shaft end float with a dial indicator. If the end float is not within specification (.003 to .008) the shaft must be removed and the bearing spacer



17. Place a new O-ring into its groove in the inner differential housing carrier and tap the outer differential housing carrier into place. Bring the rear output shaft carrier into position. Torque the (12) nuts (50/50 differential) or capscrews (26/74 differential) to specification.

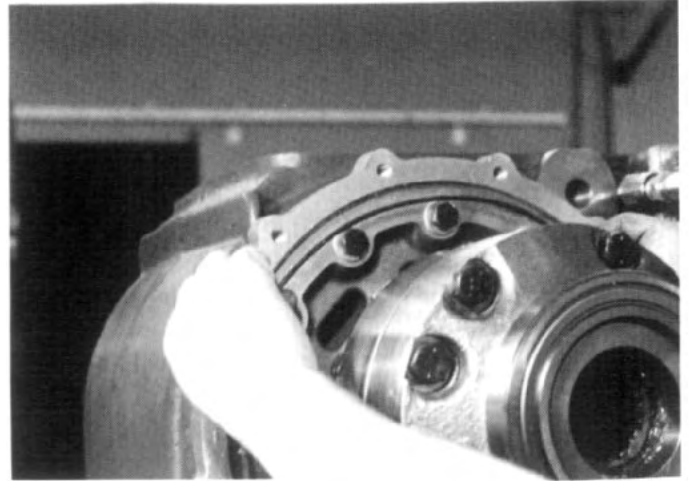

replaced with one of the proper width to obtain the correct end float.

16. Remove Tool 866 678. If working on a 50/50 ratio model, press the oil seal into the inner side of the rear output shaft carrier. The seal must be installed "backwards", i.e. the end of the seal with the spring must be visible after installation. Place a new O-ring into the inner side of the rear output shaft carrier.

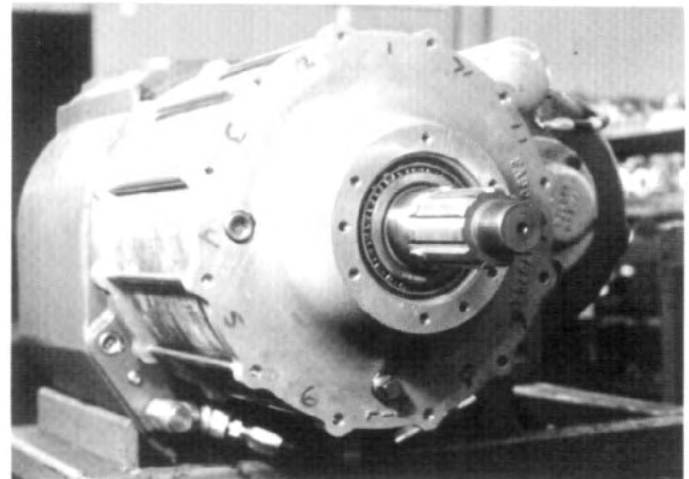
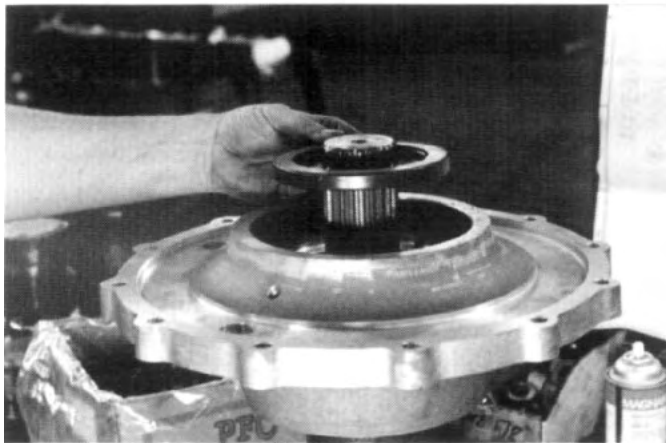
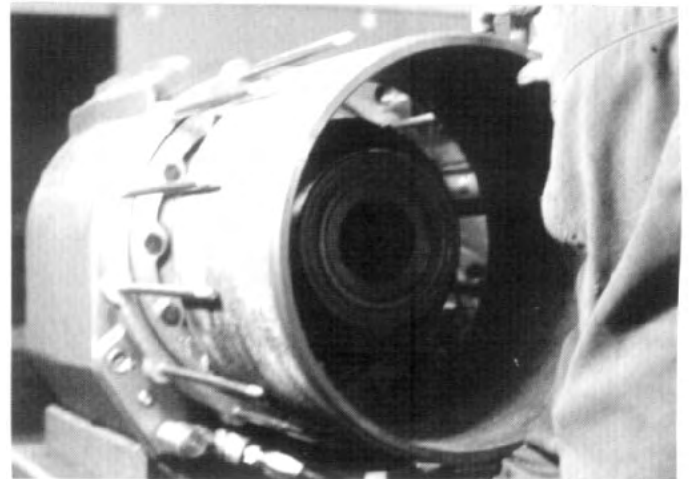

18. Add the spacer and the speedometer drive gear to the rear output shaft as shown in Fig. 6.4-11 in the Fabco TC-142 Transfer Case Parts and Service Manual. Lubricate the speedometer drive gear as shown in Fig. 6.4-12.
19. Press the rear output shaft oil seal into its carrier. Install the carrier to the rear differential housing carrier with a new gasket. Torque the (6) capscrews to specification.

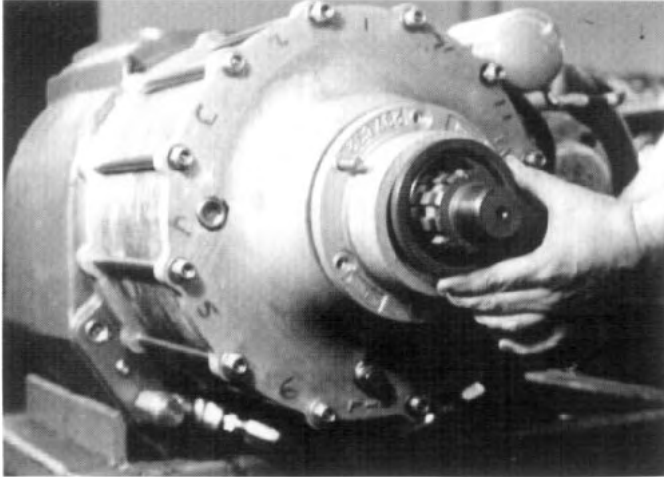

20. Complete the installation of the lower shaft assembly by following the instructions in Fig. 6.4-17 through Fig. 6.4-20 in the Fabco TC-142 Transfer Case Parts and Service Manual. Note that the end float should have been adjusted prior to Fig. 6.4-20.

6.5 SHAFT AND BEARING END FLOAT ADJUSTMENT

See Section 6.5 in the Fabco TC-142 Transfer Case Parts and Service Manual for the procedure for setting the end float of the upper and intermediate shafts.

6.6 SHIFT SHAFT ASSEMBLY AND ADJUSTMENT

See Section 6.6 in the Fabco TC-142 Transfer Case Parts and Service Manual.

6.7 PTO DECLUTCH ASSEMBLY

See Section 6.7 in the Fabco TC-142 Transfer Case Parts and Service Manual if the unit is equipped with a top rear PTO drive.

6.8 PUMP AND PLUMBING ASSEMBLY

See Section 6.8 in the Fabco TC-142 Transfer Case Parts and Service Manual if the unit is equipped with a lubrication pump.

ALL TORQUE VALUES ARE FOR DRY THREADS,
AND SHOULD BE WITHIN 10% OF VALUES SHOWN.

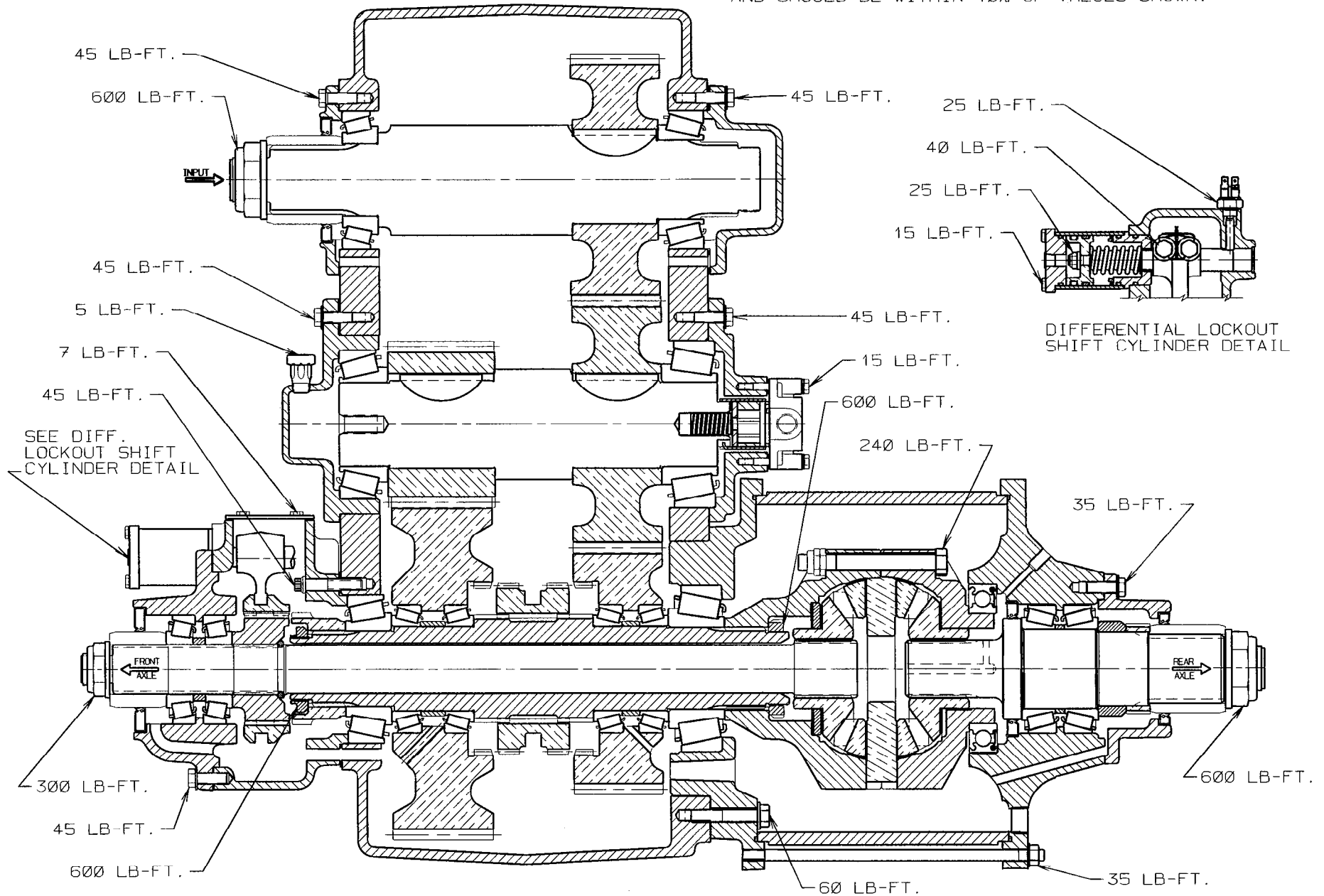

7.0 TORQUE SPECIFICATIONS

ALL TORQUE VALUES ARE FOR DRY THREADS,
AND SHOULD BE WITHIN 10% OF VALUES SHOWN.

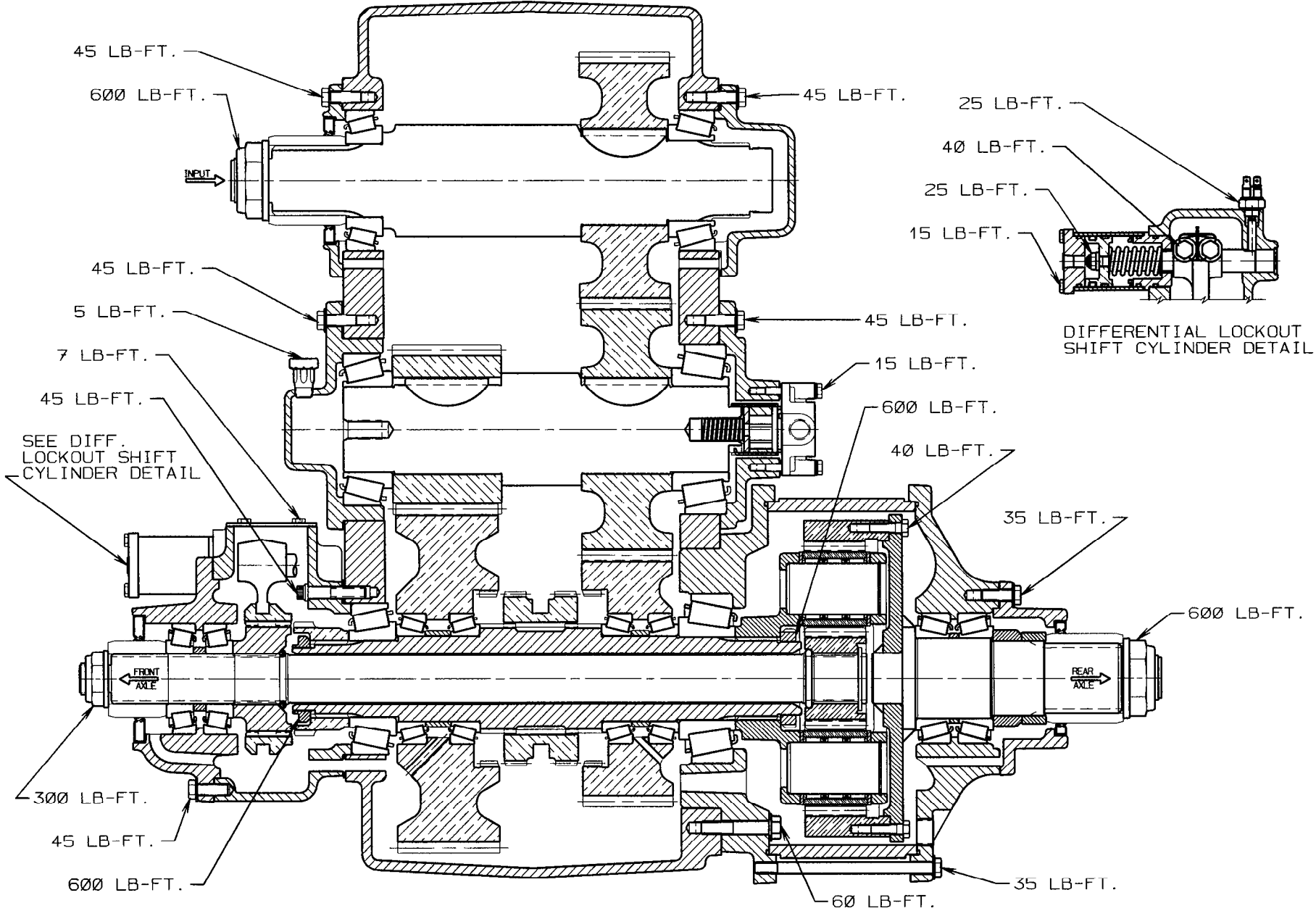

7.0 TORQUE SPECIFICATIONS

10.0 TOOLING

Details of tooling to facilitate servicing the TC-142 PD Transfer Case.

Service tools may be manufactured to these drawings or, Fabco Automotive may be contacted for a price and delivery quotation.

The manufacture of these tools should be carried out by professional machinists and certified welders, following typical good workmanship procedures and safe practices.

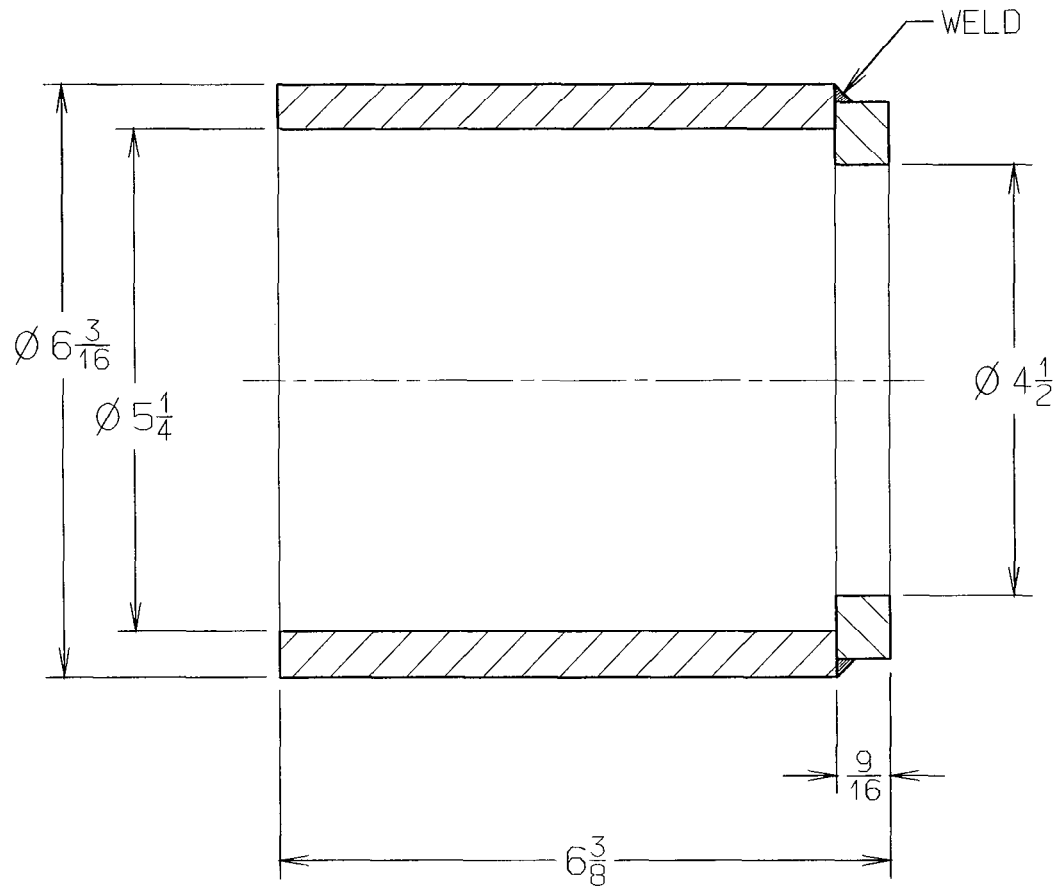

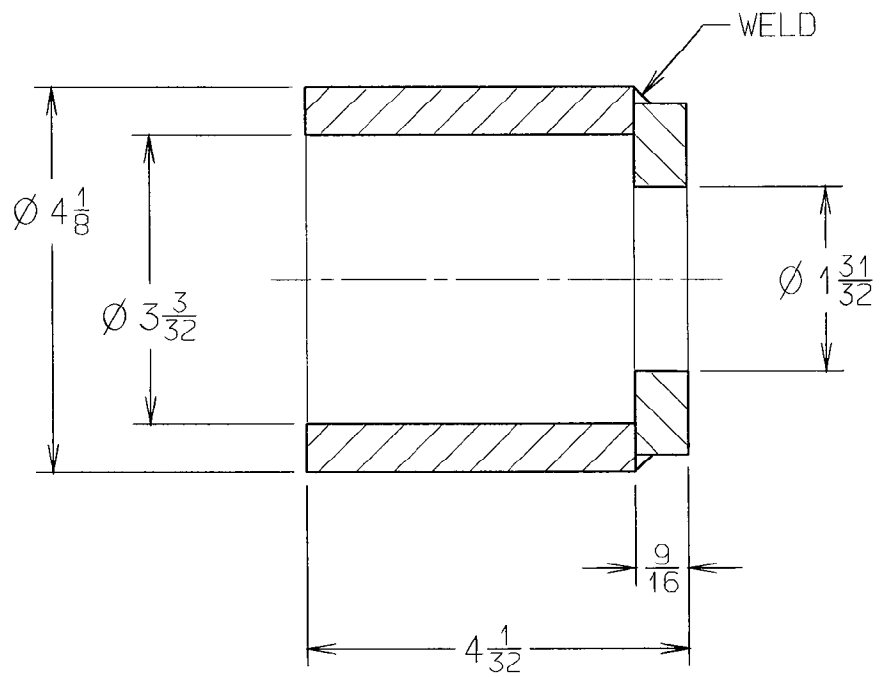

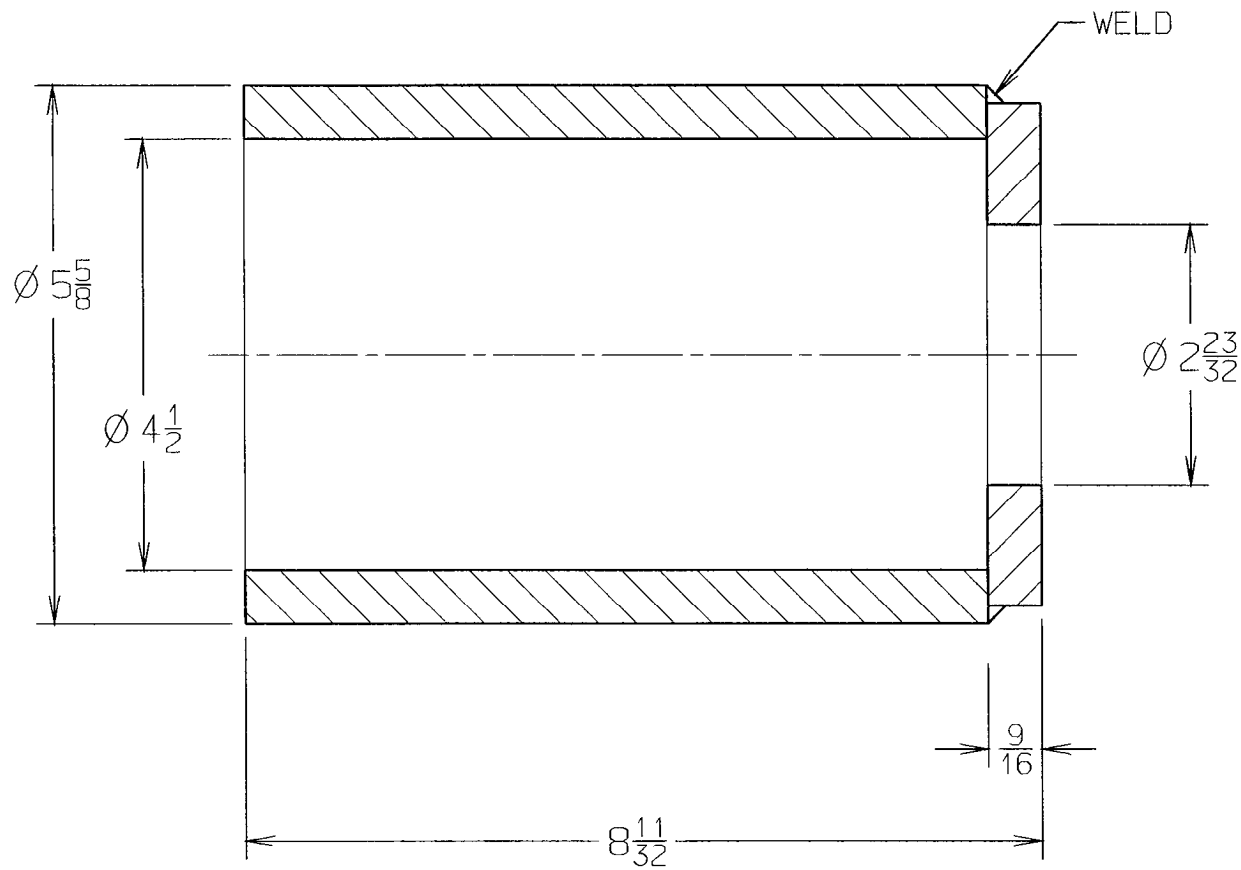

866-0678 - REAR OUTPUT PUSHER , TC-142PD

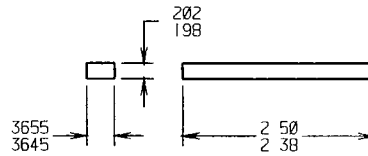
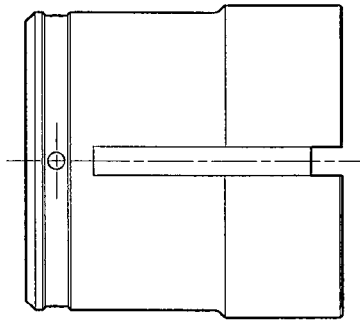

WRENCH KEY

(4) REQUIRED
MATERIAL: 4140 STEEL

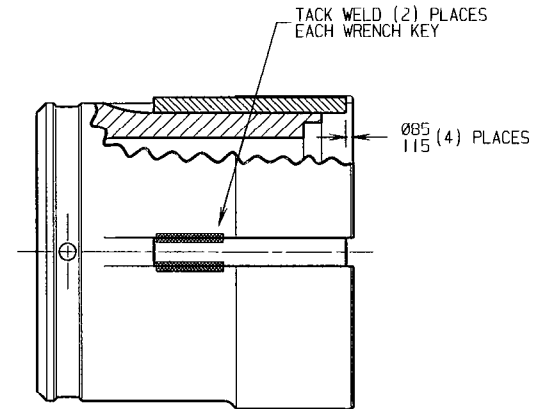

WRENCH WELDMENT

AFTER WELDING
HARDEN TO Rc 40-45

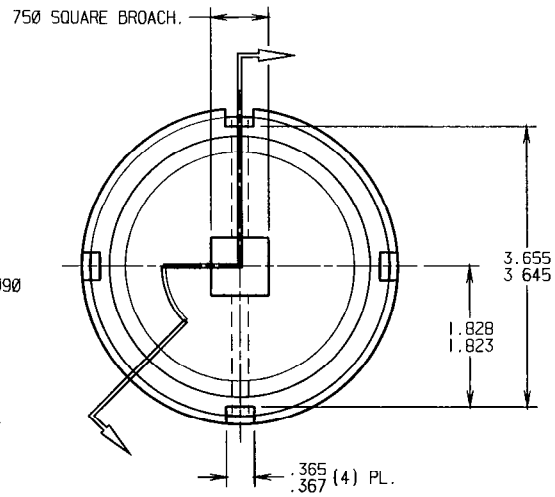
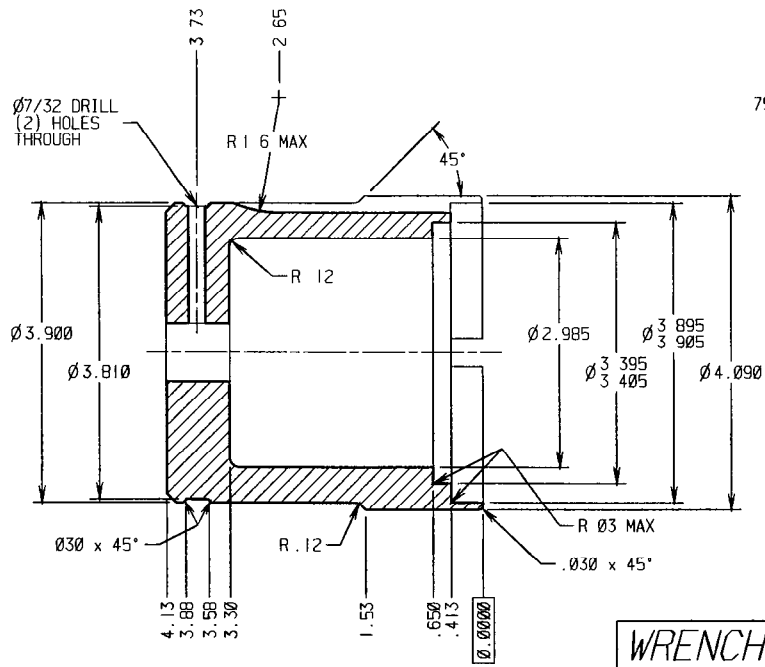

WRENCH BODY

(1) REQUIRED
MATERIAL: 4140 STEEL